

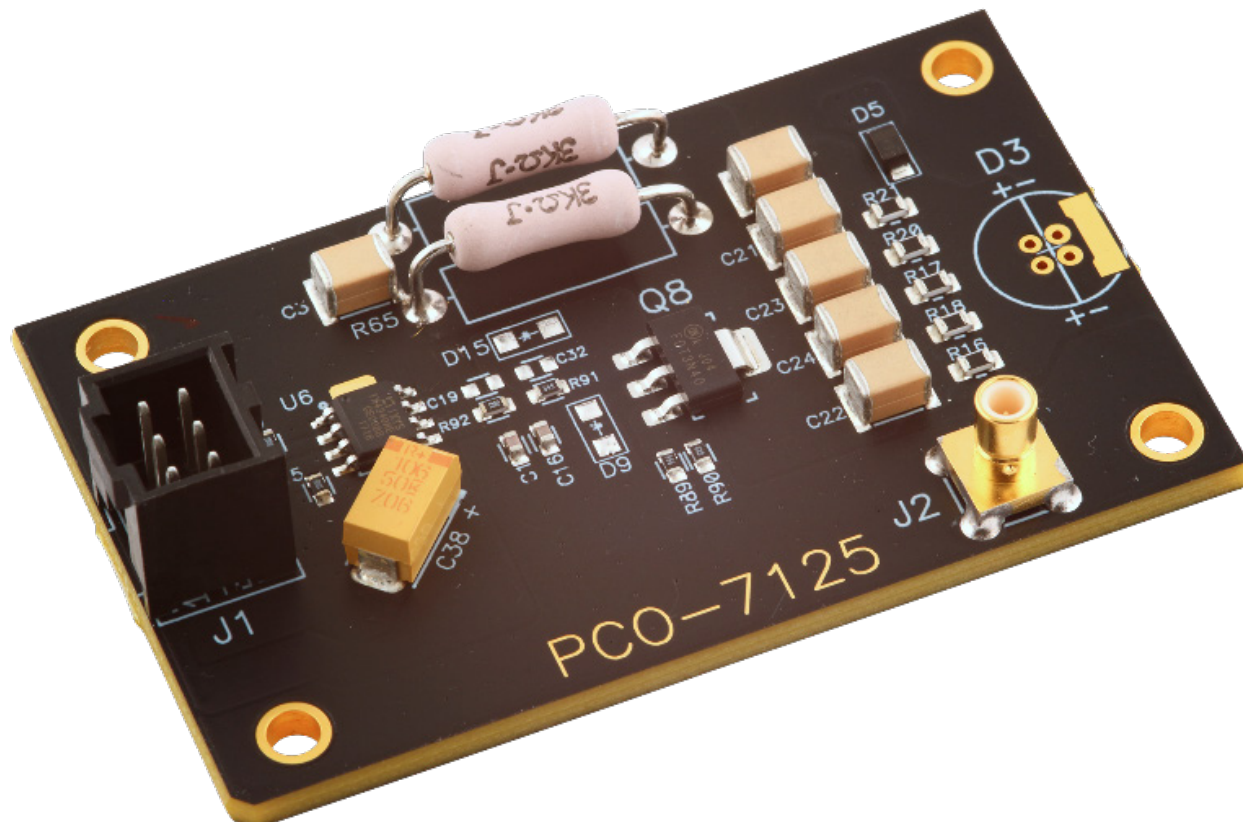

# PCO-7125

## Laser Diode Driver Module Operation Manual

---



Directed Energy, Inc.  
1609 Oakridge Dr., Suite 100, Fort Collins, CO 80525  
[sales@directedenergy.com](mailto:sales@directedenergy.com)  
[directedenergy.com](http://directedenergy.com)

For more information: **970.493.1901** or [sales@directedenergy.com](mailto:sales@directedenergy.com)  
Document #7650-0033 Rev B1. © Copyright 2018 Directed Energy Inc. All rights reserved.



# Contents

- Contents ..... 3
- Safety ..... 4
- Introduction ..... 5
  - ❖ Description ..... 5
  - ❖ Design Considerations..... 5
  - ❖ Accessories Available ..... 7
- Operation ..... 8
  - ❖ Safety ..... 8
  - ❖ Requirements..... 8
  - ❖ Setup ..... 8
  - ❖ Power Up..... 8
  - ❖ Enable the PCO-7125 ..... 9
  - ❖ Power Down..... 9
- Warranty and Service..... 10
  - ❖ Warranty ..... 10
  - ❖ Factory Service and Support ..... 11

# Safety

---

- Do not install, handle, or remove the PCO-7125 while it is operating.
- Do not use this device in a manner not specified by the manufacturer.
- Allow sufficient space around this device for air circulation.
- Do not use where liquids are present or in corrosive environments.

## **WARNING**

**Risk of lethal electric shock. Do not touch the output or laser diode while it is operating. This device produces LETHAL levels of electric current at its output.**

DO NOT OPERATE THIS DEVICE UNLESS ANOTHER PERSON, CAPABLE OF RENDERING FIRST AID OR RESUSCITATION, IS PRESENT.

SAFE AND PROPER OPERATION OF THIS DEVICE IS THE RESPONSIBILITY OF THE USER.

Directed Energy, Inc. (DEI) provides information on its products and associated hazards, but it assumes no responsibility for the after-sale operation and safety practices.

# Introduction

---

## ❖ Description

The PCO-7125 is a compact and economical OEM pulsed-current laser diode driver module. It is designed to provide extremely fast high-current pulses for driving laser diodes in range finder, LIDAR, atmospheric communications and other applications requiring high-current nanosecond pulses.

The PCO-7125 offers variable output current from 500 mA to 5000 mA with continuously variable pulse widths from 32 ns to 1  $\mu$ s and frequencies up to 865 kHz.

Mounting pads are provided to mount the laser diode directly to the driver. The four-hole mounting pattern accepts TO-18, TO-5, TO-52, 5.6 mm, and 9 mm packages.

To facilitate various packages and mounting preferences, two solder pads at the end of the board accept various laser diode packages mounted on-axis to the driver. Alternately, low-inductance stripline cable can be used to connect the board to a remotely-located diode.

The DC high voltage and +12 V DC power supplies are connected via J1, a six-pin male header connector, using the supplied control cable. Pulse current depends on HV supply voltage over the range of 0 V to +200 V (maximum). Externally-generated pulses are fed to the gate input via J1 connector. The width and repetition rate of the gate pulses directly set the timing of the output pulses.

A current monitor output is provided to observe the diode current in real time with an oscilloscope.

## ❖ Design Considerations

Many stray elements and components can affect PCO-7125 performance. One of the most important is stray inductance, which includes the output current loop's circuit elements and the physical inductance of that loop. The magnitude of this inductance has a great effect on pulse width and peak output current. The PCO-7125 design minimizes the stray inductance of the circuit components. However, the laser diode that it drives, and how the diode is connected to the PCO-7125, also contribute to stray inductance. The user can minimize this additional inductance by choosing appropriate diode packages and interconnections between the diode and driver.

The driver has four holes for convenience in mounting.

### **J1 Control Connector**

Connector J1 has the following pin connections for controlling the PCO-7125:

- Pin 1, 3, and 5: Common return for gate, 12 V, and high voltage
- Pin 2: Gate input
- Pin 4: +12 V DC input
- Pin 6: High voltage input

### **J2 Current Monitor**

These are the pin connections for the current monitor:

- Center Pin: Current Monitor (+)
- Shielding Pin: Current Monitor (-)

Connector JP1 is a Molex # 901301106 two-row header on 0.1-inch centers. The header mates with an Molex # 901420006 locking ramp plug, or equivalent.

Connector J2 (Current Monitor) is an SMB connector. The optional current monitor cable (SMB to BNC) is DEI part number PCA-9245.

The circuit board has four mounting holes in the corners of the board. The board mounting hole spacing is 54.55 mm x 30.8 mm. The hole diameter is 3.25 mm.

The operating temperature should be maintained below 35 °C. If the temperature exceeds 35 °C, additional cooling should be provided either by forced air cooling across the driver, or by mounting the board to a heat sink or cold plate using the mounting holes provided.

The PCO-7125 requires 15 minutes to thermally stabilize. When operating, adjust the PCO-7125 to the desired current, pulse width, and frequency. After the module stabilizes, readjust the current (15 minutes).

The externally generated gate signal may be input via JP1 pin 2 connector. To improve pulse fidelity, all connections should be as short as possible. The gate signal should be TTL (+3V to +5V). The voltage level of the pulse generator should be set while terminated into a 50 Ω termination (such as the 50 Ω input of an oscilloscope) prior to connection to the PCO-7125.

The output current pulse width and frequency follows the input gate width and frequency.

The PCO-7125 output current is set by the amplitude of the voltage at the high voltage input. The DC high voltage power supply charges the PCO-7125's on-board energy storage capacitors.

## ❖ Accessories Available

### Control Cable Assembly (PCA-7000)

The Control Cable Assembly is included with the PCO-7125.

### Current Monitor Cable Assembly (PCA-9245)

The Current Monitor Cable allows the user to monitor the output current pulses with an oscilloscope (BNC to SMB plugs). The current-to-voltage ratio is 2:1 (2 A per 1 V).

### Output Cable Assembly (1820-0030)

The Output Cable Assembly is an optional micro-stripline cable that allows the user to connect the PCO-7125 to a remote laser diode with minimum added inductance.

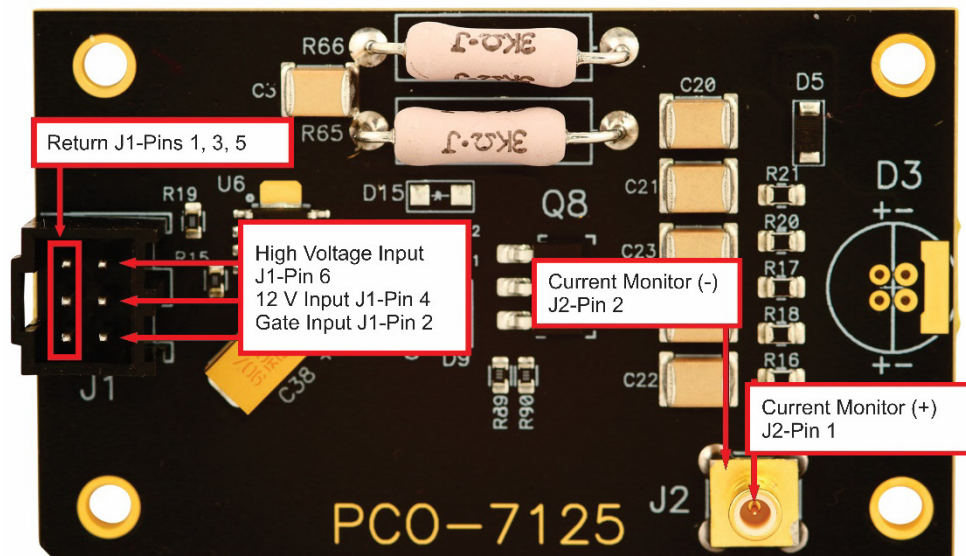

# Operation

---

## ❖ Safety

Follow the safety guidelines. DO NOT PROCEED WITHOUT UNDERSTANDING AND OBSERVING THESE GUIDELINES.

## ❖ Requirements

Verify that the PCO-7125:

- Is connected with the proper cables and the correct impedance set.
- Has its output connected to a load or output device with the proper polarity.

## ❖ Setup

1. Verify the PCO-7125 is OFF when connecting or disconnecting the laser diode or load.
2. Make the laser diode connection with the correct polarity. If necessary, review the output connector silkscreen for polarity specifications.
3. Connect the J1 inputs as follows:
  - a. Connect the gate source to J1 pin 2.
    - i. Set the external trigger source to 50  $\Omega$  impedance. Set the frequency and pulse width below the maximum specified for the PCO-7125. Review the Safe Operating Area Graphs found on the PCO-7125 datasheet for the proper frequency and pulse width values.
  - b. Connect the +12 V DC housekeeping power supply to J1 pin 4.
  - c. Connect the high-voltage power supply to J1 pin 6.
    - i. Do not enable the high voltage at this time.
    - ii. Set the high voltage to the desired value. Do not exceed 200 V DC.
  - d. Connect all returns for gate, 12 V, and high voltage to pins 1, 3, and 5.
4. Connect an oscilloscope to the current monitor if desired.
  - a. Use SMB to BNC cable PCA-9245.
  - b. Set the oscilloscope termination impedance to 50  $\Omega$ .
  - c. The current-to-voltage scale factor is 2 A/V typically.

## ❖ Power Up

1. Verify the external trigger is disabled.
2. Verify the high voltage is disabled.
3. Power up the +12 VDC power source.



## ❖ Enable the PCO-7125

1. Set the output current by varying the high voltage input. Do not exceed 200 V DC.
2. Enable the external high voltage source.
3. Set the external trigger for the desired frequency and pulse width, being careful not to exceed the maximum frequency. Review the SOA graphs to determine the maximum frequency and pulse width.
4. Enable the external trigger source.
5. Verify the output is correct with the current monitor and an oscilloscope.
6. After 15 minutes readjust the current. Do not exceed 200 V DC.

## ❖ Power Down

1. Disable the external trigger source.
2. Disable the high voltage source.
3. Power down the +12 V DC power source.

# Warranty and Service

---

## ❖ Warranty

Directed Energy, Inc. (DEI) warrants equipment it manufactures to be free from defects in materials and factory workmanship under conditions of normal use, and agrees to repair or replace any standard product that fails to perform as specified within ninety days (90) after date of shipment to the original owner. OEM, modified, and custom products are warranted, as stated above, for ninety (90) days from date of shipment to original owner. This Warranty shall not apply to any product that has been:

- I. Repaired, worked on, or altered by persons unauthorized by DEI in such a manner as to injure, in DEI's sole judgment, the performance, stability, or reliability of the product;
- II. Subjected the product to misuse, neglect, or accident; or
- III. Connected, installed, adjusted, or used otherwise than in accordance with instructions furnished by DEI.

DEI reserves the right to make any changes in the design or construction of its products at any time, without incurring any obligation to make any change whatever in units previously delivered.

DEI's sole obligation, and buyer's sole remedies, under this agreement shall be limited to a refund of the purchase price, or at DEI's sole discretion, to the repair or replacement of products in kind that prove, to DEI's satisfaction, to be defective, when returned to the DEI factory, transportation prepaid by the buyer, within the warranty period. DEI shall in no way be liable for damages consequential or incidental to defects in its products, for failure of delivery in whole or in part, for injuries resulting from its use, or for any other cause.

Returns must be preauthorized and accompanied by a DEI return authorization number.

The foregoing states the entire warranty extended by DEI, and is given and accepted in lieu of 1) any and all other warranties, expressed or implied, including but not limited to the implied warranties of merchantability and fitness for any particular purpose and 2) any obligation, liability, right, claim or remedy in contract or tort.

## ❖ Factory Service and Support

For more information about your instrument or for an operation problem, please contact the factory:

Directed Energy, Inc.  
1609 Oakridge Dr., Suite 100  
Fort Collins, Colorado 80525  
(970) 493-1901

[sales@directedenergy.com](mailto:sales@directedenergy.com)  
[support@directedenergy.com](mailto:support@directedenergy.com)  
[directedenergy.com](http://directedenergy.com)

